

# Fully Integrated Rugged Systems Solutions

## “THE FIRST FOURTEEN WEEKS OF THE SCHEDULE SHOWS COTS MODULE INTEGRATION AND TEST. CAN WE SHORTEN THAT?”

Now you can. Imagine hitting the ground running with your next rugged system design by leveraging existing Commercial Off The Shelf (COTS) technology from world leading providers. Imagine focusing your critical time and attention on the application at hand rather than the underlying computing modules. Imagine starting your program with a running qualified computer, instead of a kit.

Acme Embedded Solutions are COTS module integration experts. Leveraging our experience in rugged COTS based turnkey systems, spanning over a decade, we know the tricks and traps that a systems integrator can

encounter when assembling their system from disparate modules. We specialize in making it all work together, so you don't have to.

Employing state of the art test facilities and fixtures, Acme guarantees operation of ruggedized modules to your program requirements, and backs it up with MIL-SPEC qualification test results. From technology sourcing through to system installation and training, Acme Embedded Solutions is your supplier of choice for integrated COTS flight ready systems that meet your demanding environmental standards.

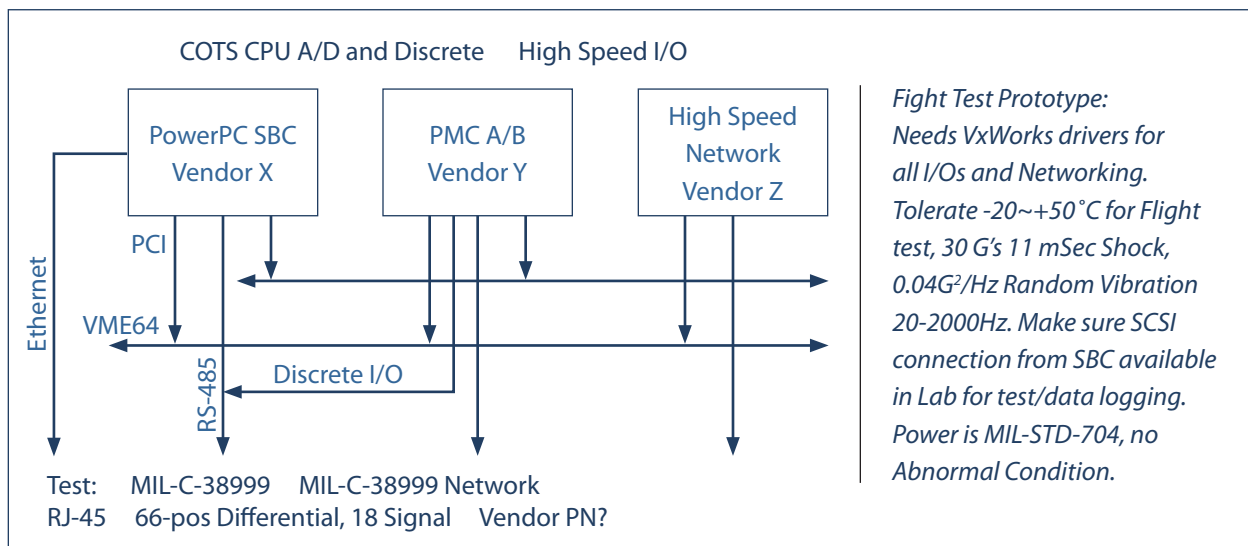

Conceptually, a fully integrated system looks logical and straightforward... until you run into the details of cabling, connectors, inter module compatibility, and device driver conflicts. When a system calls for modules from multiple vendors, a simple problem can be very, very frustrating to solve. Acme Embedded Solutions uses a proven integration process including proprietary software integration tools and verification procedures that get all the modules in the system working together. And we deliver that system ready to run YOUR application software right out of the box, Guaranteed.

## NOW YOU CAN: CALL ACME EMBEDDED SOLUTIONS WITH YOUR PROGRAM REQUIREMENTS

**Get A Full  
Power Start**

www.acme-embedded.com  
Phone: (775) 691-2100 • Fax: (775) 201-4469  
Email: sales@acme-embedded.com  
350 South Center St. Suite 500 • Reno, Nevada 89501

